

Bourdon tube pressure gauge Model 113.53, standard version with liquid filling

WIKA data sheet PM 01.08

Applications

- For measuring points with high dynamic pressure loads or vibrations
- For gaseous and liquid media that are not highly viscous or crystallising and will not attack copper alloy parts
- Hydraulics
- Compressors

Special features

- Vibration and shock resistant
- Especially robust design
- Stainless steel case
- Scale ranges up to 0 ... 400 bar



Bourdon tube pressure gauge model 113.53

Description

Design

EN 837-1

Nominal size in mm

40, 80, 100

Accuracy class

NS 40: 2.5

NS 80, 100: 1.6

Scale ranges

0 ... 1 to 0 ... 400 bar

or all other equivalent vacuum or combined pressure and vacuum ranges

Pressure limitation

Steady: 3/4 x full scale value

Fluctuating: 2/3 x full scale value

Short time: Full scale value

Permissible temperature

Ambient: -20 ... +60 °C

Medium: +60 °C maximum

Temperature effect

When the temperature of the measuring system deviates from the reference temperature (+20 °C): max. $\pm 0.4 \%$ /10 K of the span

Ingress protection

IP 65 per EN 60529 / IEC 529

Standard version

Process connection

Cu-alloy,
lower mount (LM) or centre back mount (CBM),
NS 40: G 1/8 B (male), 14 mm flats
NS 80: G 1/2 B (male), 22 mm flats
NS 100: G 1/2 B (male), 22 mm flats

Pressure element

< 60 bar: Cu-alloy, C-type
≥ 60 bar: Cu-alloy, helical type

Movement

Cu-alloy

Dial

Aluminium, white, black lettering, with pointer stop pin

Pointer

Aluminium, black

Window

Plastic, crystal-clear

Case

Natural finish stainless steel, with blow-out device at case circumference, 12 o'clock.

Scale ranges ≤ 0 ... 16 bar with compensating valve to vent case

Bezel ring

Crimp ring, glossy finish stainless steel, triangular bezel

Filling liquid

Glycerine 99.7 %

Options

- NS 80, 100: Panel mounting flange, stainless steel, for back mount connection
- NS 80, 100: Surface mounting flange, stainless steel

Dimensions in mm

Standard version

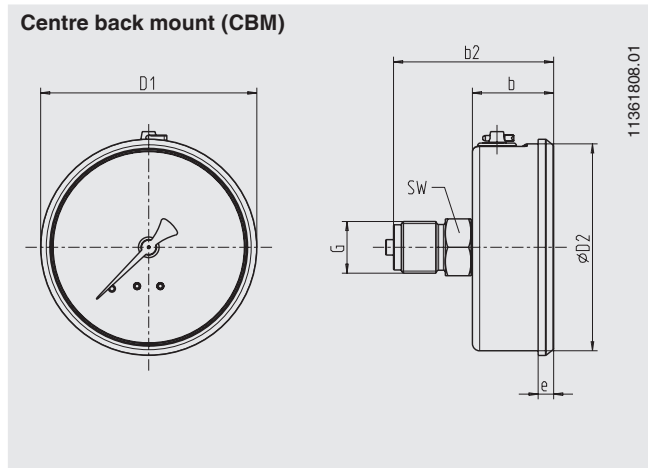
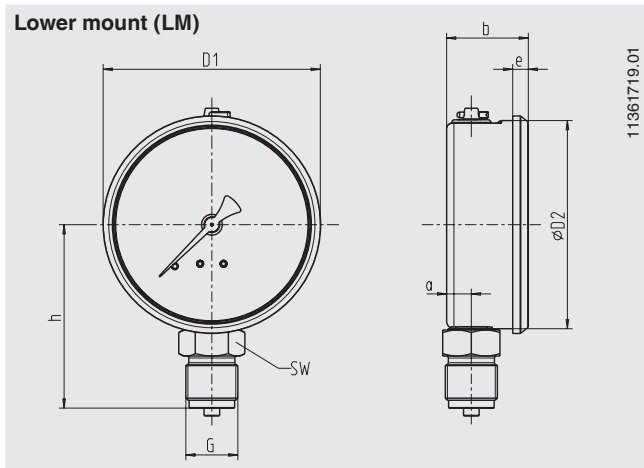

NS	Dimensions in mm									Weight in kg
	a	b ± 0.5	b ₂ ± 0.5	D ₁	D ₂	e	G	h ± 1	SW	
40	9.5	28	50	46.5	40	6	G 1/8 B	40.5	14	0.15
80	9.5	32	62.5	83.5	80	5.5	G 1/2 B	70.5	22	0.35
100	10.5	34.5	65	106.5	100	8	G 1/2 B	80.5	22	0.55

Process connection per EN 837-1 / 7.3

Ordering information

Model / Nominal size / Scale range / Connection size / Connection location / Options

© 2009 WIKA Alexander Wiegand SE & Co. KG, all rights reserved.
The specifications given in this document represent the state of engineering at the time of publishing.
We reserve the right to make modifications to the specifications and materials.

